

### FEATURES

- 2 1/2 digit, 10mm character height display
- Display On-Hold option (VK1000/H)
- 200mV full scale input sensitivity
- 10 pA input current typical
- Automatic polarity
- Easy panel mounting
- 12 Annunciators on display
- Easy to use decimal point and annunciators
- 9V or 5V operation
- Reflective Mode

### ORDERING INFORMATION

#### MODEL

VK1000	Without	} Built-in display hold (9V version only)
VK1000-5/9	Without	} Built-in display hold with 5V operating capability
VK1000H	With	} Built-in display hold (9V version only)
VK1000H-5/9	With	} Built-in display hold with 5V operating capability

### ELECTRICAL CHARACTERISTICS (T<sub>o</sub>=+25°C)

CHARACTERISTIC	CONDITION	MIN	TYP	MAX	UNITS
Supply Voltage (VDD)	9 Volts Option 5 Volts Option	7 4.5	9 5	10 6.0	Volts Volts
Supply Current (IDD)	9 Volts Option 5 Volts Option	— —	100 2	500 3	μA mA
Leakage Input Current		—	1	10	pA
Reference Voltage (Factory Adjusted)	For 9 Volts Option only	—	100.0	—	mV
Full Scale		—		200	mV
Zero Input Reading		—	±0.000	—	Count
Accuracy (Input at 199.5mV)	9 Volts Option 5 Volts Option	— —	±2 ±2	±4 ±4	Count
Linearity (Max. Deviation From Best Straight Line)	9 Volts Option 5 Volts Option	— —	±1 ±1	— —	Count
Resolution		—	100	—	μV
Sampling Rate		—	3	4	Read/Sec
CMRR		—	70	—	dB
Temp Coefficient		—	100	150	ppm/°c

### OPERATING SPECIFICATIONS

Operating Temperature	0°C to +50°C
Storage Temperature	-40°C to +70°C
Operating Relative Humidity	90% Max.

### DEFINITION OF TERMINALS

PIN	DESCRIPTION	PIN	DESCRIPTION
<b>VDD</b>	Positive supply terminal	<b>C</b>	Analog common
<b>VSS</b>	Negative supply terminal for 9V option	<b>XBP</b>	For driving annunciators
<b>INHI</b>	Positive input terminal	<b>BP</b>	LCD Back Plane.
<b>INLO</b>	Negative input terminal	<b>D1,D2,D3</b>	Decimal Point. D1=.000, D2=0.00, D3=00.0. The decimal point will appear when these pins are tied to XBP
<b>GD</b>	For H version HOLD1 must be connected to GD for continuous display updating	<b>BAT,C,F,-,m,μ,</b>	Annunciators.
<b>RH</b>	Reference High terminal	<b>Mn,Kn,V,A,HOLD2</b>	
<b>RL</b>	Reference Low terminal		
<b>HOLD1</b>	Connect to VDD for display freeze and to GD for continuous updating		

### 5 VOLTS / 9 VOLTS OPERATING VOLTAGE CONFIGURATION

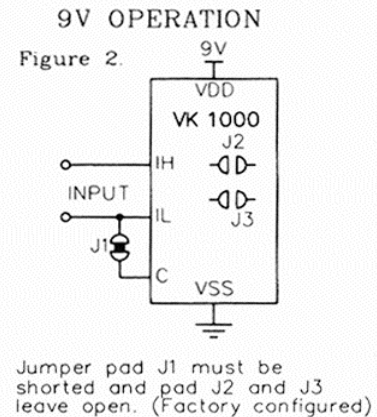
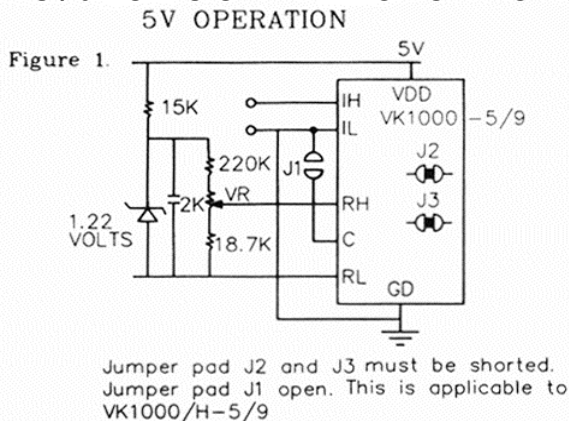

**NOTE** VK1000/H is calibrated for 9 volts operation. For 5 volts operation, it has to be recalibrated. With external reference connected as shown in Figure 1, without external reference, fluctuation of supply will affect the calibration. with 100 millivoltson input, adjust VR to read 1000 on display.

### USERS' INSTRUCTIONS

The module is ready for general use when connected according to figures above. The input range is set for 200mV full scale. If the input signal exceeds 200mV the module will go into an over-range condition blanking the three least significant digits. The number "1" will be displayed in the most significant digit. In cases of high input impedance, this condition could occur without an applied signal. To avoid this condition, place a 10M resistor across the input terminals. With the resistor in place, the display will indicate 000 as long as no input signal is applied. The module has automatic zero adjustment, therefore, manual zero adjustment is unnecessary. If the input voltage polarity is correct with respect to IH and IL the display will indicate the correct polarity. With reverse polarity, a minus sign will be displayed. The input terminals must not be connected directly to either VDD or VSS to avoid latch-up of IC.

For 9 volts operation, it is recommended to power the module with 9 volts battery. It is intended that the inputs float with respect to the 9 volts supply. In general, if the inputs do not float with respect to the supply, the inputs must be no closer than 1.5 volt from either VDD or VSS ( $VDD-1.5/VSS+1.5$ ).

VK1000 is designed to operate at 9 volt, however if 5 volt option is needed, external reference is required as shown in Figure 1. With this connection module would have to be calibrated before use. This can be easily done by connecting the module as in Figure 1. above, then with 199.0 mV applied to the inputs, adjust the trimmer resistor, VR, until the display shows 1990. With 5 volts supply the module can have either floating or non-floating inputs.

Module with hold feature must have the terminal HOLD1 connected to GN for a continuous updated display. With HOLD1 terminal at VDD level the display will be put on-hold.

**NOTE :** FOR APPLICATION PLEASE REFER TO VK1760/1763 INFRONT.